

A Significant Advantage...

SUN'S FLOATING STYLE SCREW-IN CARTRIDGE

- ▶ Maximum design flexibility with consistent port usage, and optimized port connection areas.
- ▶ Utilizes a minimum number of cavities for 2-, 3-, 4-, and 6-port cartridges thus reducing cavity tooling requirements.
- ▶ 5 cartridge sizes allow flows ranging from 0.25 gpm (1 L/min.) to 200 gpm (760 L/min.).
- ▶ High operating pressures: 5000 psi (350 bar) for all cartridge functions.
- ▶ Cartridge types are interchangeable, without compromising equipment performance.

Sun's free-floating subassembly tolerates eccentricity between cavity and cartridge nose.

The flat shoulder provides a generous area stop, against which the cartridge thread load reacts. Being a flat area, there is minimal induced compressive radial load, causing cartridge distortion and binding, and allows a higher installation torque, with less sensitivity to over-torque damage. Higher installation torques minimize cartridge backing out under hydraulic cycling.

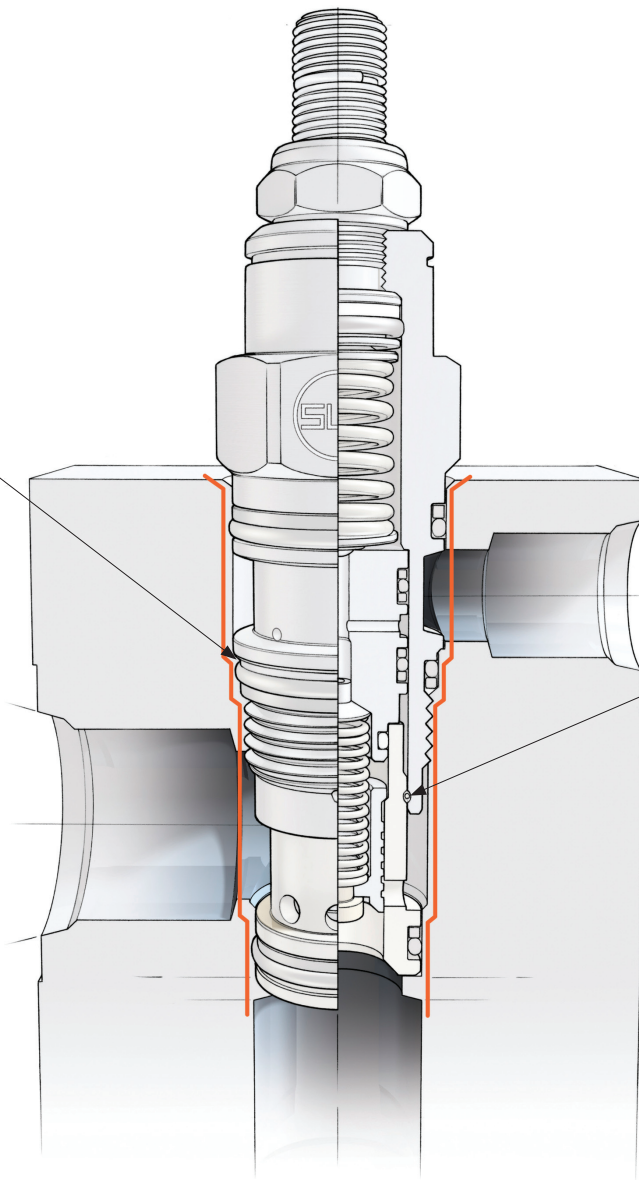

For a given thread size, the central location of the thread position results in maximum flow capacity, minimizes the effect of eccentricity, and distributes thread loads deep into the manifold.

The shoulder diameter at the threads provides a guide to ensure the threads are adequately centered.

The stop at the bottom of the cavity supports the free-floating cartridge subassembly during operation: critical working parts don't bind during operation. The retaining ring is used only for assembly.